

## ANALOG TO RESISTANCE ATR167

### DESCRIPTION

The ANALOG TO RESISTANCE ATR167 can convert most process signals into a simulated resistance output along with 3-way galvanic isolation up to 2000V r.m.s. between input signal, resistance output and power supply.

The conversion technique is analogue thus providing infinite resolution. Typical application include:

- Convert a thermocouple to RTD signal to match dissimilar existing equipment
- Automatic gain control.

The output signal level is indicated by a green L.E.D. on the front of the module, giving a clear indication of module function, signal presence and loop condition for current outputs. Various power supply choices are available ranging from 240Vac down to 8Vdc. All provide power isolation and surge protection.

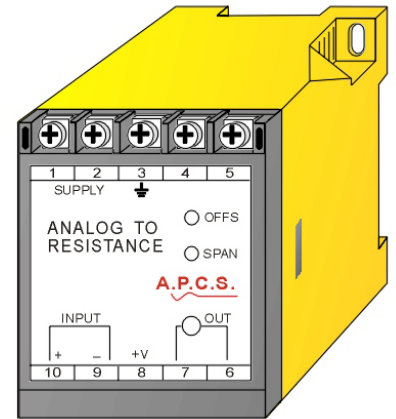

### General Specifications

Size: 52 W x 70 H x 110 D (mm).  
 Housing material: Polycarbonate.  
 Mounting: DIN-Rail, gear plate.  
 Termination: Screw terminals on front  
 Terminal covers standard.

Protection class: IP40 (IP65 Enclosure opt.).  
 Weight: 0.370 kg.  
 Accuracy: 0.15% of span.  
 Front 'OFFS' adjust: ±20% typical  
 Front 'SPAN' adjust: ±20% typical  
 Linearity: 0.2% of span.  
 Repeatability: 0.1% of span.  
 Response time (input/output): 0.5 sec for T90 standard  
 0.06 seconds selectable  
 10 milliseconds selectable.

Output response time: ≅ 10mS  
 (This is how quickly the output circuit can simulate resistance in response to changes to excitation in the customer equipment).

Standard Input Impedance: 51Ω (20mA/10mA range).  
 1kΩ (1mA range).  
 2M7Ω (10V/5V range).  
 560kΩ (2V/1V range).

Temperature effect: 0.025% per °C.  
 Operating temp. range: -10...-60°C.  
 Storage temp. range: -20...+70°C.  
 Input/output isolation: >2kV r.m.s.  
 Power requirements: ac supply 4W, dc supply 3W.

Electromagnetic compatibility: Complies with AS/NZS 4251.1 (EN 50081.1)

Minimum output resistance: ≅1% of range.  
 Resolution: Continuous.  
 Maximum applied voltage: 5V peak (dc – 100Hz).

Maximum current: 
$$= \frac{5V}{\text{max\_resistance\_of\_range}}$$
 not exceeding 5mA

Minimum current: 
$$= \frac{50mV}{\text{max\_resistance\_of\_range}}$$
 for reasonable stability.

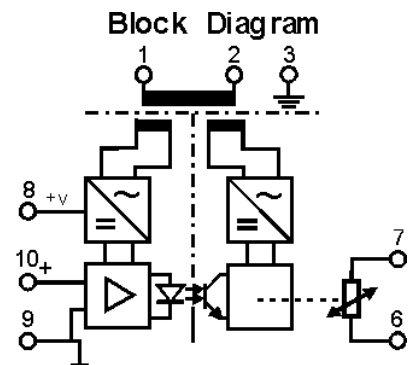

The output resistance range cannot be zero based. Output minimum should not be smaller than 1% of output maximum. eg 10....1000 Ω.

Output can simulate Pt100 RTD e.g. 100.0-138.5 Ω equates to 0-100°C.

Maximum and minimum current sinking depends on range ordered, typical values are:

Range	Max Current	Min Current
1MΩ	5μA	50nA
100kΩ	50μA	500nA
10kΩ	0.5mA	5μA
5kΩ	1mA	10μA
1kΩ	5mA	50μA
100Ω	5mA	0.5mA

TYPE NO. DESIGNATION

ATR167 - X XX X XX

**Power Supply:**

- 1 = 240V, 50/60Hz ±10%.
- 2 = 120V, 50/60Hz ±10%.
- 3 = 24V, 50/60Hz ±10%.
- \*) 6 = 8 - 60Vdc Isolated
- \*) 8 = 60 - 240Vdc Isolated.
- \*) 9 = Other (Specify).

**Input:**

- 01 = Process link table 1.
- \*) 02 = Millivolt link table 2.
- \*) 03 = RTD.
- \*) 04 = Thermocouple.
- \*) 05 = Frequency. Calibration range 0 - 10Hz...0 - 5kHz (Sine, Triangle)  
Sensitivity: 200mVpp. (70mV r.m.s.) min. 22Vpp. max (Square, Pulse).
- \*) 06 = Pulse input from NAMUR proximity sensor or passive device (contact, open collector).  
Auxiliary supply of 8Vdc at terminal 8, other data as option 05.
- \*) 07 = Bipolar / millivolt. (±0.5mV to ±2kV bipolar) (1mV to 2kV unipolar).  
It may be more cost effective to use an alternate range.
- \*) 08 = Resistance (constant current excitation).
- \*) 09 = Potentiometer 3W voltage excited.
- \*) 99 = Other (Specify).

Specify type of sensor and calibration details.

**Output:**

- 1 = Resistor (Specify).

**Options:**

- 00 = None.
- \*) 08 = Customised response time.
- \*) 99 = Other (Specify).

**Process link table 1 SW1**

Input	1	2	3	4	5	6	7	8
4-20mA		X	X	X				X
0-1mA	X		X	X			X	
0-10mA		X	X	X	X		X	
0-20mA		X	X	X			X	
0-1V			X	X			X	
0-2V			X				X	
0-5V				X			X	
1-5V				X				X
0-10V							X	

**Millivolt link table 2 SW1**

Input	1	2	3	4	5	6	7	8
0-20mV			X	X	X	X	X	
0-40mV			X	X	X			
0-50mV			X	X	X		X	
0-60mV			X	X		X		
0-75mV			X	X		X	X	
0-100mV			X	X			X	
0-150mV			X		X		X	
0-200mV			X				X	
0-250mV				X	X		X	
0-500mV				X			X	
0-750mV					X		X	
0-1000mV							X	

**Response Time Table 3 SW1**

Response time	9	10
10msec		
60msec	X	
500msec		X

**To change ranges:**

- 1) Disconnect power to unit.
- 2) Unclip housing lid and withdraw unit from housing.
- 3) Set the coding plugs as required.
- 4) Reassemble unit and connect power.
- 5) Adjust "span" and "offs" pots to recalibrate.
- 6) Change the label information to the new input/output values.

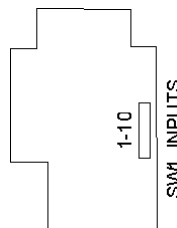

Factory default range: 4-20mA input 0.5 sec Response.

\*) = Price Extra.

In the interest of development and improvement, A.P.C.S. Pty. Ltd. reserve the right to amend, without notice, details contained in this publication. A.P.C.S. PTY. LTD. will accept no legal liability for any errors, omissions or amendments.