

ANALOGUE TO PULSE CONVERTER (v3) APC153

DESCRIPTION

The series 100 APC153 is an analogue to pulse converter that is factory configured for a wide range of voltage (1mV to 100Vdc) current (1mA to 1Adc) and sensor inputs while providing true 3-way galvanic isolation up to 1500Vdc. The output frequency range can be factory calibrated for any frequency span from 10Hz up to 10kHz, with low scale frequency offsetting also available. e.g. 0 - 10Vdc in = 1 - 2kHz out. The input/output configuration can also be set for reverse action if required. Final calibration is trimmed using the front accessible 'offs' and 'span' 15-turn trim adjustments. The output pulse amplitude is adjustable via the 15-turn reference front potentiometer, which allows exact pulse voltage levels to be set. The module output is indicated by a front mounted L.E.D. which provides clear indication of module function and frequency output. Power supply variations from 240Vac down to 8Vdc all providing isolation of 2kVr.m.s. / 2.5kVdc. RF and power transient protection is standard as it is with all A.P.C.S. modules.

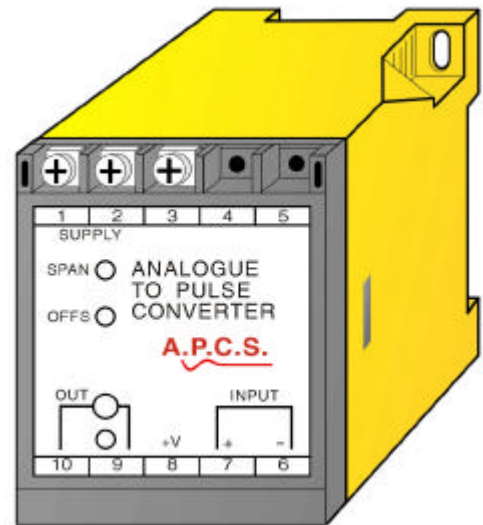

General Specifications

Size:	52 W x 70 H x 110 D (mm).
Mounting:	DIN-Rail, gear plate.
Termination:	Top mounted screw terminals.
Protection class:	IP40 (IP55 Enclosure Opt).
Weight:	0.300 kg.
Housing material:	Polycarbonate.
Calibration accuracy:	±0.2% of SPAN.
Front 'SPAN' adjust:	±10% typical.
Front 'OFFS' adjust:	±10% typical.
Repeatability:	±0.2% of SPAN.
Combined linearity and drift error:	±0.50% of SPAN.
Temperature effect:	Typically 0.02% of span per °C.
Operating temperature:	-10...+50°C.
Power supply voltage fluctuation effect:	For ±10% fluctuation 0.5% of range.
Output frequency range:	10Hz to 10kHz. For output pulse frequencies 10Hz and below refer to LI152.
Pulse voltage level:	1.0 up to 24Vdc (adjustable).
Output pulse drive:	20mA maximum.
Output transistor rating:	30V, 100mA.
Input/output isolation:	1000Vac r.m.s./1500Vdc.
Power requirements:	ac supply 4W, dc supply 3W.
Electromagnetic compatibility:	Complies with AS/NZS 4251.1 (EN 50081.1)

Block Diagram

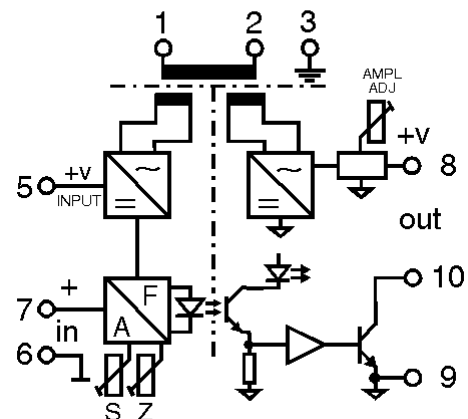

For input / output combinations refer to TYPE NO. DESIGNATION overleaf.

TYPE NO. DESIGNATION

APC153 - X X XX X X X

Power Supply:

- | | |
|------------------------------|------------------------------|
| 1 = 240V, 50/60Hz \pm 10%. | *) 5 = 8 - 60Vdc Isolated. |
| 2 = 120V, 50/60Hz \pm 10%. | *) 6 = 12Vdc (use '5'). |
| 3 = 24V, 50/60Hz \pm 10%. | *) 8 = 60 - 240Vdc Isolated. |
| *) 4 = 48Vdc (use '5'). | *) 9 = Other (Specify). |

Input:

- | | | |
|---------------------------------|--|----------------------------------|
| # 1 = 4 - 20mA (100 Ω). | 5 = 0 - 5V (200k Ω). | *) 9 = Optional input see below. |
| 2 = 0 - 20mA (100 Ω). | 6 = 1 - 5V (200k Ω). | |
| 3 = 10 - 50mA (50 Ω). | 7 = 0 - 10V (470k Ω). | |
| 4 = 0 - 1V (200k Ω). | *) 8 = Other DC voltage (>100mV <2kV) or current (5A max). | |
- # Includes 24Vdc / 22mA auxiliary output on terminal 5.

Output:

- | | | | |
|-----------------|-----------------|-----------------|------------------|
| 01 = 0 - 50Hz. | 06 = 0 - 300Hz. | 11 = 0 - 800Hz. | 16 = 0 - 4kHz. |
| 02 = 0 - 100Hz. | 07 = 0 - 450Hz. | 12 = 0 - 900Hz. | 17 = 0 - 5kHz. |
| 03 = 0 - 150Hz. | 08 = 0 - 500Hz. | 13 = 0 - 1kHz. | 18 = 0 - 7.5kHz. |
| 04 = 0 - 200Hz. | 09 = 0 - 600Hz. | 14 = 0 - 2kHz. | 19 = 0 - 10kHz. |
| 05 = 0 - 250Hz. | 10 = 0 - 700Hz. | 15 = 0 - 3kHz. | |
- *) 99 = Other - span or live zero (Specify). Live Zero example 20 - 100Hz.

Pulse Ref. Level:

- | | |
|--------------------------------------|--|
| 1 = 1 - 5Vdc. | *) 3 = Current pulse (0mA low, 20mA high). |
| 2 = 4 - 24Vdc (4 - 21Vdc, DC power). | |

Action:

- | | |
|-------------|--------------|
| 1 = Direct. | 2 = Reverse. |
|-------------|--------------|

Options:

NOTE:- Specify type of sensor and calibration details.

- | | |
|----------------------------------|------------------------------------|
| 0 = None. | *) 5 = RTD (Pt100) input (2 wire). |
| *) 1 = AC voltage input. | *) 6 = Thermocouple input. |
| *) 2 = AC current input. | *) 7 = (Hz) Frequency input. |
| *) 3 = Millivolt input (<100mV). | *) 8 = pH (REDOX) input. |
| *) 4 = Resistance input 2-Wire. | *) 9 = Other (Specify). |

Connection Notes

Terminal 5 has +24Vdc 4-20mA input models only. This voltage should only be used with loop powered transmitters on the input.

Front Panel Controls

- Span adjustment (Full scale)
- Offset adjustment (Start off scale)
- Output pulse amplitude adjustment

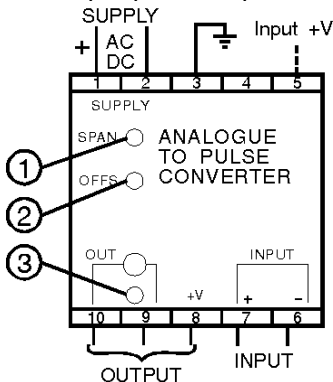

Voltage Output Connection

Low = 0V
High = Voltage set by amplitude adjustment

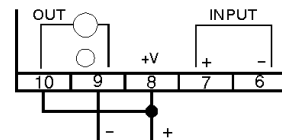

Current Output Connection

Low = 0V High = 20mA
RL = Instrument Input.

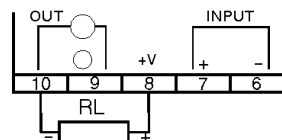

Open Output Connection (externa supply)

Low = Closed High = Open

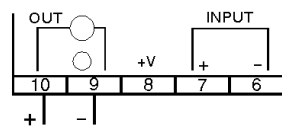

*) Price Extra.

In the interest of development and improvement, A.P.C.S. Pty. Ltd. reserve the right to amend, without notice, details contained in this publication. A.P.C.S. PTY. LTD. will accept no legal liability for any errors, omissions or amendments.